

# INSTRUCTION MANUAL

FOR

## BROTHER CB3-B913

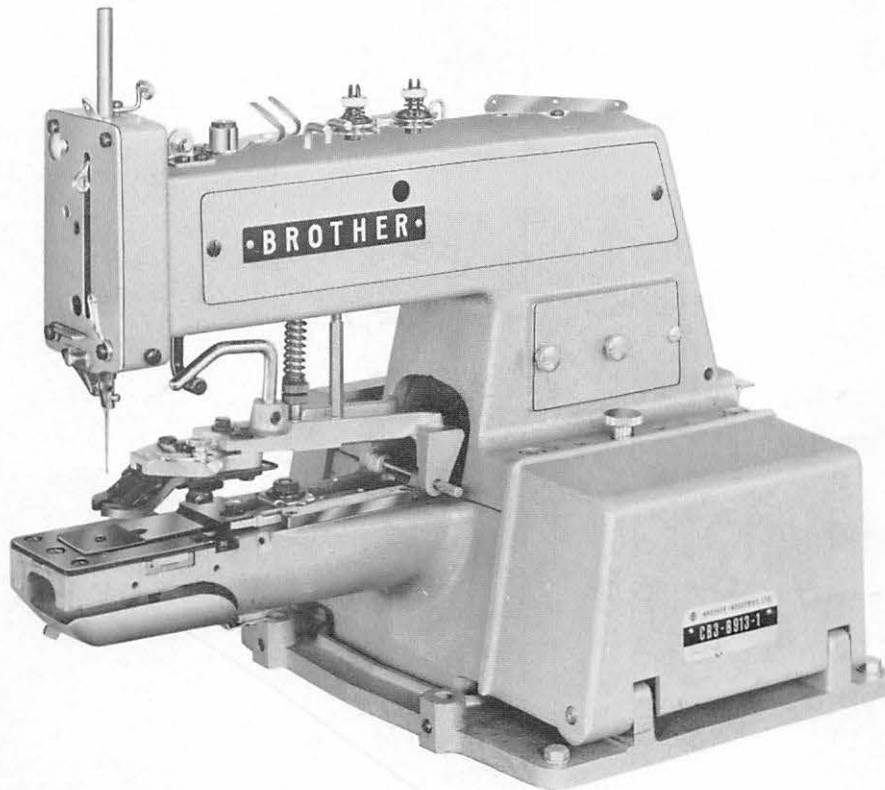

**Chain Stitch Buttoning Machine**

**BROTHER INDUSTRIES, LTD.**

**NAGOYA, JAPAN**

## ◎ FEATURES

- ★ Model CB3-B913 is an ideal machine for sewing buttons onto knitwork, dress shirts, working clothes, ladies garments and children's clothing.
- ★ The number of stitches can be easily changed to 8, 16 or 32 with simple lever operation so the machine can be used in a wide range of button sewing work.
- ★ The button clamp is automatically raised and lowered for better sewing efficiency.
- ★ A unique brake minimizes stopping shock and assures a quiet stop.
- ★ Attachments may be installed for easy pearl button sewing etc.





## CONTENTS

<b>SPECIFICATIONS</b> .....	1	<b>5. Needle Installing</b> .....	4
<b>INSTALLING</b> .....	1	<b>6. Threading</b> .....	4
1. Motor Base .....	1	<b>7. Thread Tension</b> .....	5
Motor Pulley .....	1	<b>8. Adjusting Needle Thread Length from Needle Eye after Sewing</b> .....	5
2. Setting up the Machine .....	1	<b>9. Adjusting the Button Clamp Pressure</b> .....	5
3. Installing the Button Tray .....	2	<b>STANDARD ADJUSTMENTS</b> .....	5
<b>LUBRICATION AND TRIAL OPERATION</b> .....	2	1. Needle Bar Height Adjustment .....	5
1. Oiling .....	2	2. Needle and Looper Timing Adjustment .....	5
2. Trial Operation .....	2	3. Needle Clearance Adjustment .....	6
<b>CORRECT OPERATION</b> .....	3	4. Needle Guard Adjustment .....	6
1. Longitudinal and Transversal Feed Positioning .....	3	5. Thread Looper Timing Adjustment .....	6
2. Button Insertion .....	4	6. Sub-Tension Adjustment .....	6
3. Changing the Number of Stitches .....	4	7. Button Clamp Lifter Adjustment .....	6
4. Needle and Thread .....	4	<b>TROUBLESHOOTING</b> .....	7

# SPECIFICATIONS

Sub-class	-1	-2
Stitch type	Single chain stitch, single needle, single thread (JIS C11)	
Speed	1,500 rpm	
Sewable button size	8 to 30 mm in outside diameter 2.5 to 6.5 mm in button hole spacing.	
Number of stitches	8, 16, 32	6, 12, 24
Needle bar stroke	48 mm	
Needle	TQ×1 for flat button sewing TQ×7 for shank button sewing	

Button clamp lift	Standard 14 mm, Maximum 20 mm	
Motor (single-or three-phase)	4P, 250 W motor	
Belt diameter	6.5 mm $\phi$ round leather belt	
Stitch Form	Flat button	
	Shank button	

# INSTALLING

## 1. Motor Base

In case of using a commercial motor, select one of those shown below.

Power requirements	Motor
Single-phase	4P, 250 W motor
Three-phase	4P, 250 W motor

## Motor Pulley

Select the correct motor pulley from the table below which suits the power source frequency of your area.

Source frequency	Machine speed	Motor pulley	
		Outside diameter	Pulley
50 Hz	1,500 rpm	75 mm	N-75 pulley
60 Hz	1,500 rpm	65 mm	N-65 pulley

※In case of using a commercial table, drill holes as shown below.

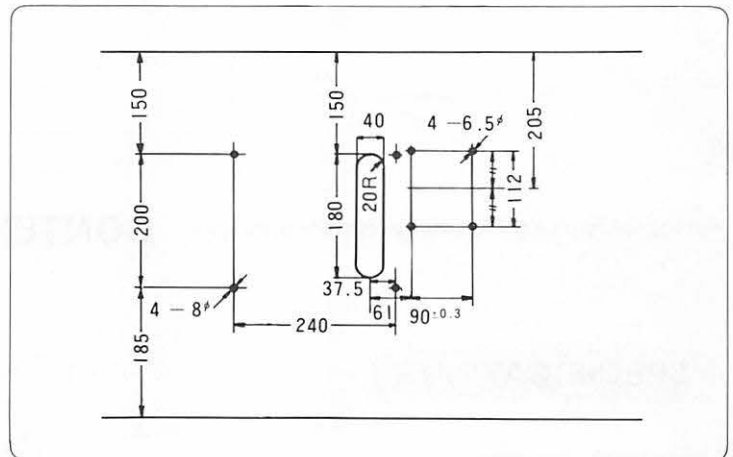

## 2. Setting up the Machine

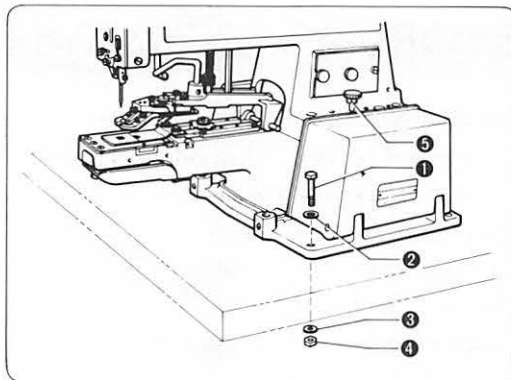

- Place the machine head on the table, and fasten the head with four hexagonal bolts ①, flat washers ②, washers ③ and nuts ④.

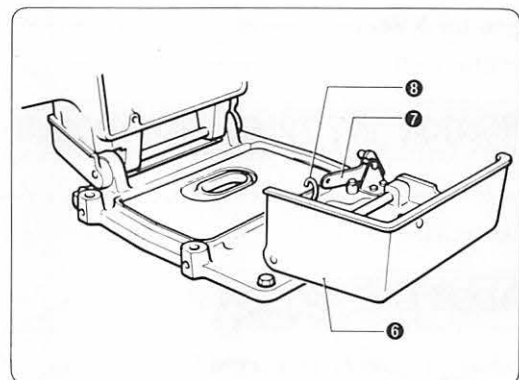

- Loosen the head clamp bolt ⑤, open the bed cover ⑥, tilt the machine head to the left, and hook the chain ⑧ to the clutch actuating lever ⑦.

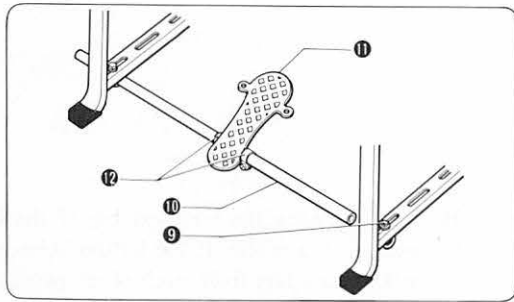

3. Loosen the two hexagonal bolts ⑨ from the table legs, disconnect one end of the support shaft ⑩, slide the pedal ⑪ and pedal stoppers ⑫ onto the shaft, and tighten the pedal stoppers ⑫ with screws.

※Adjust the pedal position with the support shaft ⑩ in the forward-backward directions, and with the pedal stoppers ⑫ in sidewise directions, making sure that the chain will contact neither the motor pulley nor the oblong hole in the table.

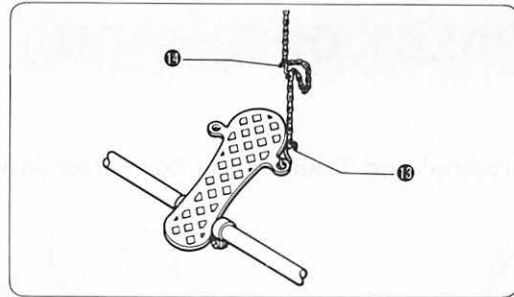

4. Connect the hook ⑬ at the lower end of the chain to the pedal, and adjust the chain length with the other hook ⑭.

### 3. Installing the Button Tray

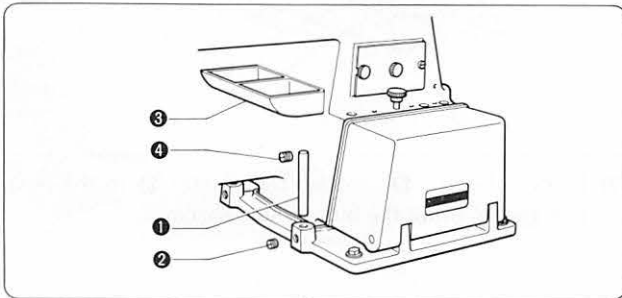

1. Take the two button tray legs ① from the parts box, insert them into the mounting holes in the bed, and fasten them with the screws ②.
2. Fit the button tray ③ onto the button tray legs ①, and fasten it with the screws ④.

## LUBRICATION AND TRIAL OPERATION

### 1. Oiling

Be sure to pour a drop or two of oil into each of oiling points indicated by arrows before starting your sewing machine.

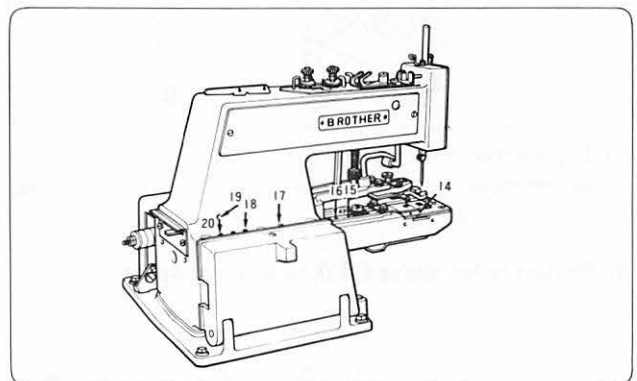
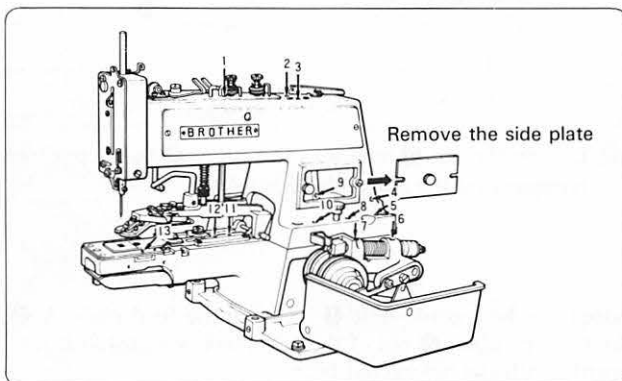

### 2. Trial Operation

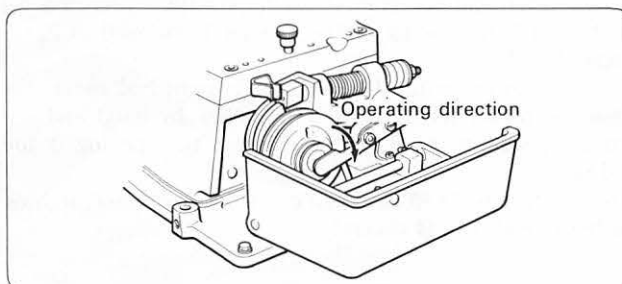

1. Switch the power on to start the motor, which drives the pulley in the arrow direction.  
※Be sure to check the operating direction of the machine.
2. The machine starts running when the pedal is stepped on.
3. Release the pedal quickly.
4. The machine sews the preset number of stitches and stops.
5. The presser foot automatically rises.  
Repeat steps 2 through 5 a few times.

# CORRECT OPERATION

## 1. Longitudinal and Transversal Feed Positioning.

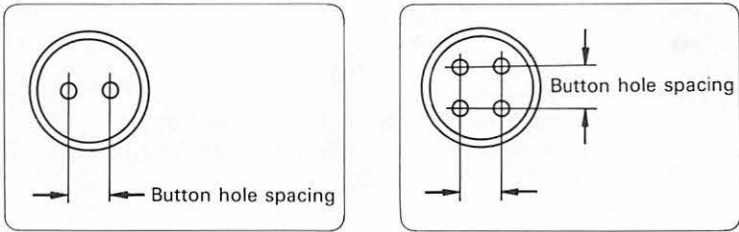

Be sure to check the hole spacing of the buttons to be sewn onto a fabric. If the button holes are spaced 2.5 to 4.0 mm apart from each other, proceed as mentioned in steps 1 and 2. If the button holes are spaced 4.0 to 6.5 mm apart from each other, take steps 1, 2 and 3.

### 1. Two-hole buttons

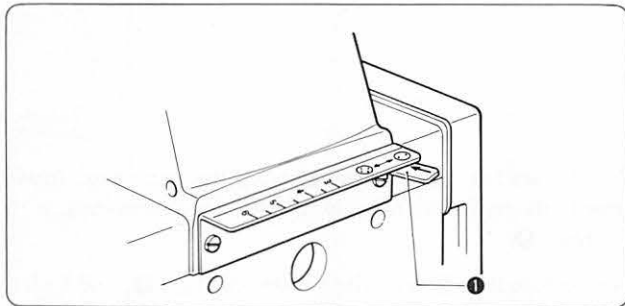

(1) Depress the lever **1** and align the arrow on the lever with the  $\odot$  mark.

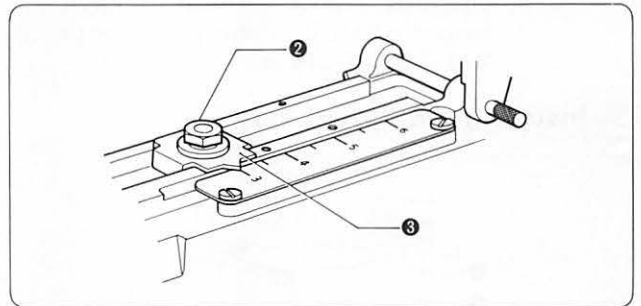

(2) Loosen the nut **2**, and set the pointer **3** to the position representing the button hole spacing.

### 2. Four-hole buttons

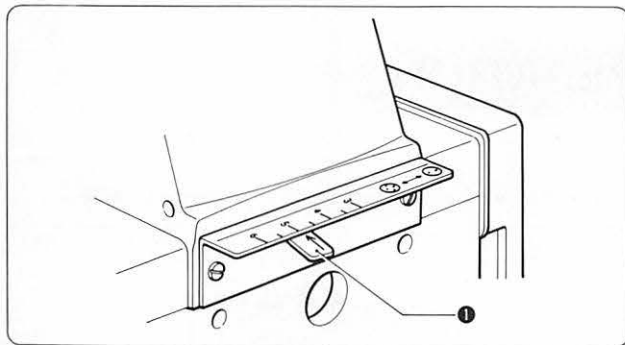

(1) Depress the lever **1** and move the arrow on the lever to the position representing the button hole spacing.

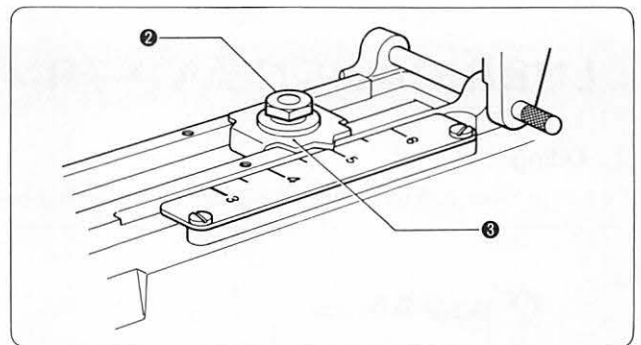

(2) Loosen the nut **2**, and set the pointer **3** to the position representing the button hole spacing.

### 3. Button holes spaced 4.0 to 6.5 mm apart.

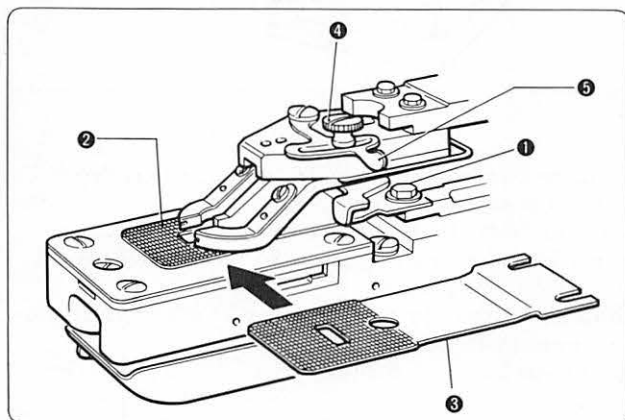

- (1) Loosen the hexagonal bolt **1**, remove the feed plate A **2**, take the feed plate **3** out of the parts box, and install it temporarily with the hexagonal bolt.
- (2) Loosen the set screw **4**, push the adjusting plate **5** all the way, and retighten the set screw **4**.
- (3) Set the lever and the pointer to the positions representing the button hole spacing in the manner mentioned in Paragraphs 1 and 2.
- (4) With the power switch OFF, open the right bed cover, depress the pedal, turn the machine pulley by hand and see that the needle will not hit the edges of the opening in the feed plate.
- (5) After the feed plate **3** has been correctly positioned, tighten the hexagonal bolt **1** securely.

## 2. Button Insertion

### 1. Two-hole buttons.

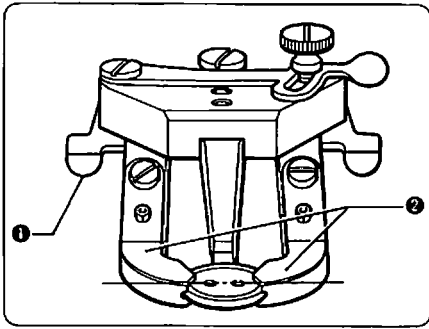

- (1) When the cam plate ① is pushed, the button clamp ② opens.
- (2) Insert a button into the clamp in the correct direction as shown above, and release the cam plate ①.

### 2. Four-hole buttons.

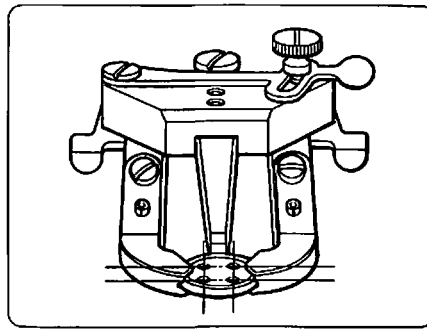

### 3. Sewing on same-sized buttons continually.

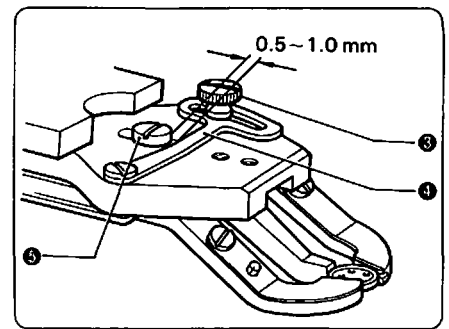

Insert a button into the button clamp, and make sure that the button has been securely gripped. With the button gripped by the clamp, loosen the set screw ③, pull the adjusting plate ④ toward yourself until there is a clearance of about 0.5 to 1.0 mm between the adjusting plate ④ and the screw ⑤. Then tighten the set screw ③.

## 3. Changing the Number of Stitches.

Turn the power switch OFF at the normal machine stop position, open the left bed cover, and depress the pedal as you select a desired number of stitches as follows.

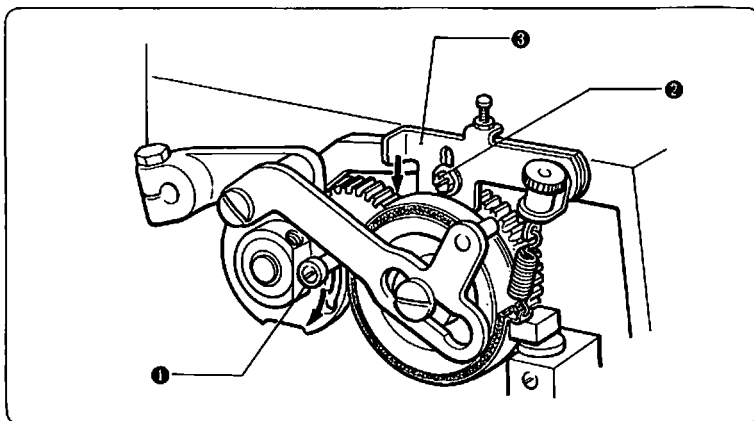

### 1. 8 stitches

The figure at left shows the case of 8 stitches.

### 2. 16 stitches

Pull the stitch select knob ① toward yourself and move it in the arrow direction.

### 3. 32 stitches

- (1) Pull the stitch select knob ① toward yourself and move it in the arrow direction.
- (2) Loosen the hexagonal bolt ②, push down the lever ③ in the arrow direction, and retighten the hexagonal bolt ②.

## 4. Needle and Thread

Needle	Size of thread	Kind of thread
# 9	# 100 to # 80	Cotton, silk
# 11	# 80 to # 60	" "
# 14	# 60 to # 40	" "
# 16	# 40 to # 30	" "
# 18	# 30 to # 24	" "
# 20	# 30 to # 16	" "

Select a needle and thread by referring to the above table.

※Use a TQ×1 needle for sewing flat buttons on; a TQ×7 needle for shank buttons.

## 5. Needle Installing

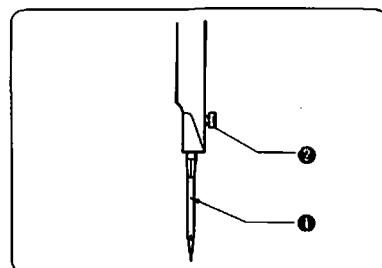

Hold the needle with its long groove side ① facing in your direction, insert the needle into the needle bar hole all the way, and clamp it with the screw ②

## 6. Threading

Pull the thread while pressing the button.

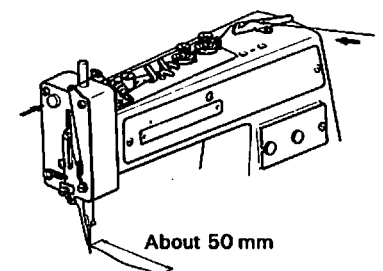

### 7. Thread Tension

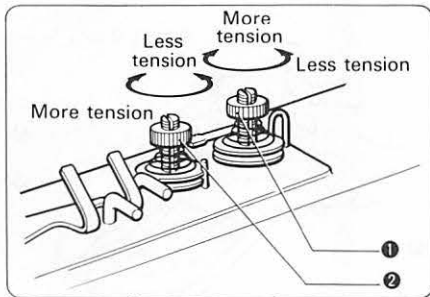

Adjust the thread tension with the main tension screw ① and sub-tension screw ②.

### 8. Adjusting Needle Thread Length from Needle Eye after Sewing

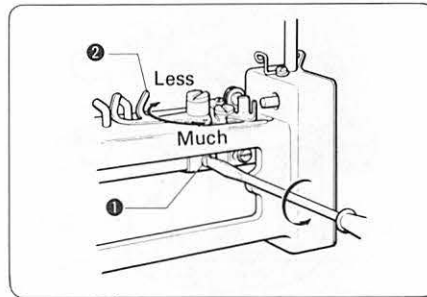

To adjust remaining thread length from the needle eye, loosen the lever adjuster screw ① and move the thread take-up lever ② as appropriate. The standard length is from 50 to 60 mm.

### 9. Adjusting the Button Clamp Pressure

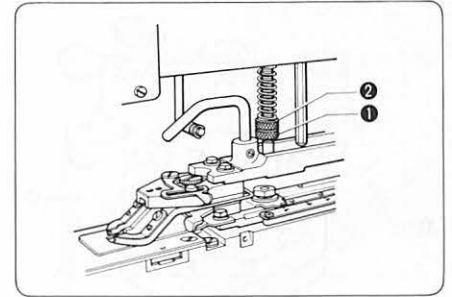

Loosen the adjusting screw ①, and turn the adjusting screw ② to adjust the button clamp pressure until it is so reduced that it can just hold the work when the work is lightly pulled. After the adjustment, lock the adjusting screw ② with the adjusting screw ①.

## STANDARD ADJUSTMENTS

### 1. Needle Bar Height Adjustment

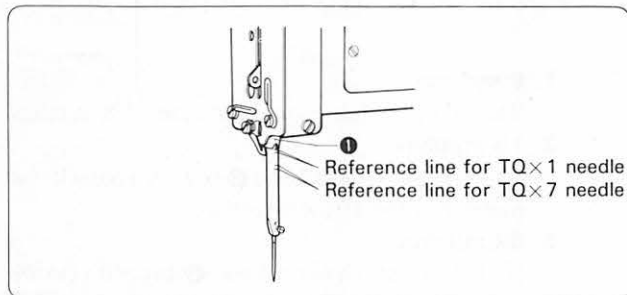

(1) When the needle falls to the lowest position, the highest of the four needle bar reference lines will be flush with the bottom end of the needle bar lower bushing ①.  
 ※In case a TQ×7 needle is used, the second lowest of the reference lines will be flush with the same.

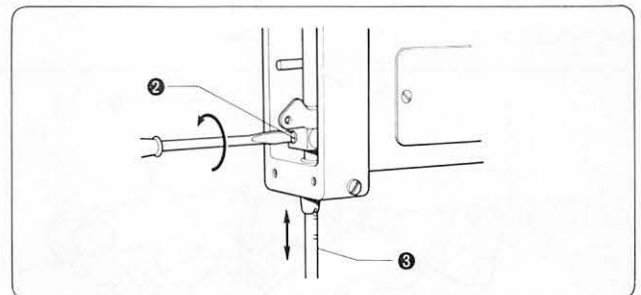

(2) Remove the face plate, loosen the needle bar holder screw ②, and raise or lower the needle bar ③ as appropriate.



### 2. Needle and Loper Timing Adjustment

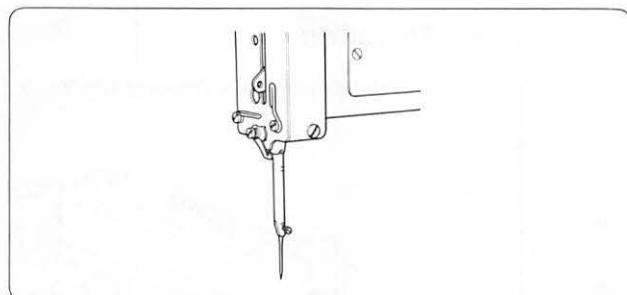

(1) When the second highest of the reference lines is flush with the bottom end of the needle bar lower bushing as the needle rises from its lowest position, the tip of the looper will be in line with the center of the needle.  
 ※In case a TQ×7 needle is used, the same is true when the lowest reference line matches the bottom of the needle bar lower bushing.

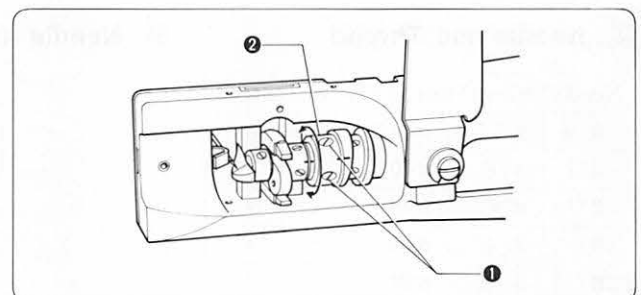

(2) Open the looper cover, loosen the screw ①, and turn the looper shaft ② until the tip of the looper is in line with the center of the needle.



### 3. Needle Clearance Adjustment

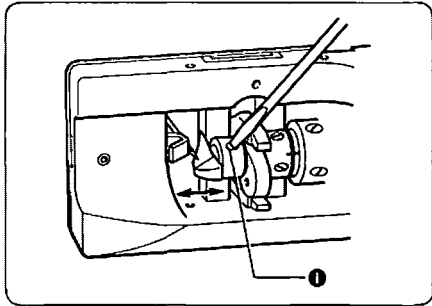

Loosen the set collar screw ① and move the looper to adjust the clearance between the needle and the tip of the looper to 0.03 to 0.08 mm when the tip of the looper is in line with the center of the needle.

### 4. Needle Guard Adjustment

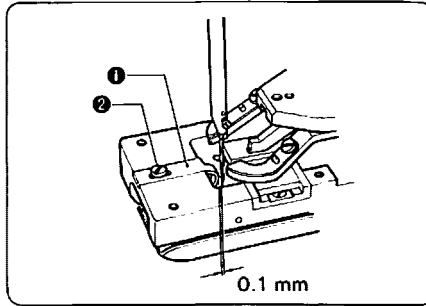

Loosen the screw ② and move the needle guard ① to adjust the clearance between the needle and the needle guard ① to about 0.1 mm.

### 5. Thread Loooper Timing Adjustment

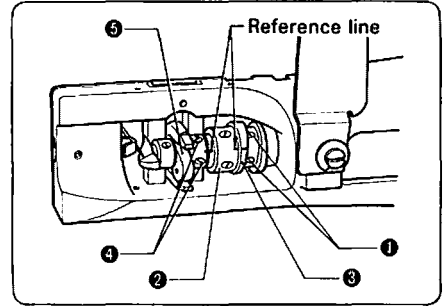

1. Loosen the screw ①, and align the reference line on the groove cam ③ with that on the looper shaft ②.
2. Loosen the screw ④, and align the reference line on the thread looper triangle cam ⑤ with that on the looper shaft ②.

### 6. Sub-Tension Adjustment

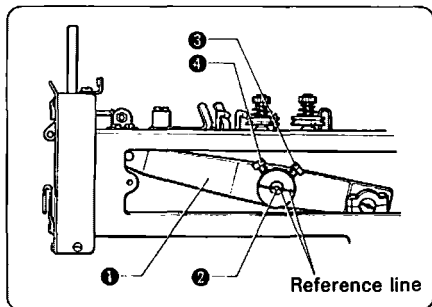

1. Check to see that the reference line on the needle bar drive lever ① matches the reference line on the needle bar drive lever shaft ②. If these reference lines are unaligned, make an adjustment by loosening the hexagonal bolts ③ and ④.

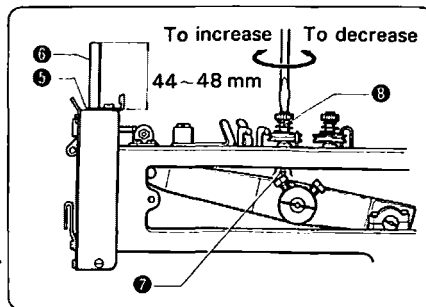

2. Turn the pulley by hand to raise the needle bar until the top of the needle bar ⑥ is 44 to 48 mm above the top end of the needle bar upper bushing ⑤. At this time, the tension disc must begin to float. Loosen the screw ⑦ and turn the sub-tension stud ⑧ until the above-mentioned timing is obtained.

※In case a TQ×7 needle is used, the tension disc must begin floating when the top of the needle bar is 54 to 58 mm above the top of the needle bar upper bushing.

### 7. Button Clamp Lifter Adjustment

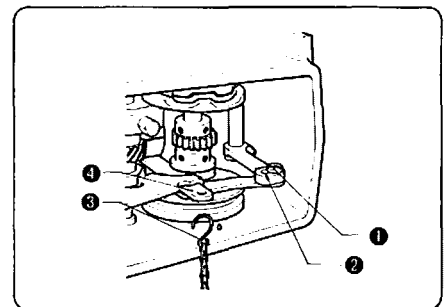

When raising or lowering the button clamp by means of the pedal.

1. Remove the screw ①, move it into the hole ②, and retighten the screw ①.
  2. Hook the chain ③ into the hole in the button clamp connecting rod ④.
- ※The pedal and chain are optional.



# TROUBLESHOOTING

Trouble	Cause	Check point	Remedy	Page
<b>Needle breaks.</b>	Button inserted improperly.	Button hole direction.	Insert button so its holes are in the correct direction.	4
	Longitudinal feed lever and pointer positioned improperly.	Longitudinal feed lever and pointer positions.	Adjust longitudinal feed lever and pointer to button hole spacing.	3
	Wrong thread looper timing.	Thread looper timing.	Adjust thread looper timing.	6
<b>Stitches skip.</b>	Wrong needle and looper timing.	Needle and looper timing.	Adjust needle and looper timing.	5
	Too great a clearance between needle and looper.	Needle clearance.	Adjust clearance between needle and looper.	6
	Needle bar height incorrect.	Needle bar height.	Adjust needle bar height.	5
	Too great a clearance between needle and needle guard.	Clearance between needle and needle guard.	Adjust needle guard.	6
	Remaining thread length too short.	Remaining thread length.	Adjust remaining thread length.	5
	<b>Stitches loose.</b>	Sub-tension disc floats improperly.	Tension disc float.	Adjust sub-tension disc float.
Sub-tension too weak.		Sub-tension tension.	Adjust sub-tension tension.	5
<b>Thread breaks.</b>	Needle installed incorrectly.	Needle direction.	Install needle with its long groove facing front.	4
	Sub-tension disc float timing wrong.	Tension disc float timing.	Adjust sub-tension.	5
	Needle too thin for thread.	Needle and thread.	Refer to instructions for needle and thread.	4

